

MONORACE LA SERIES

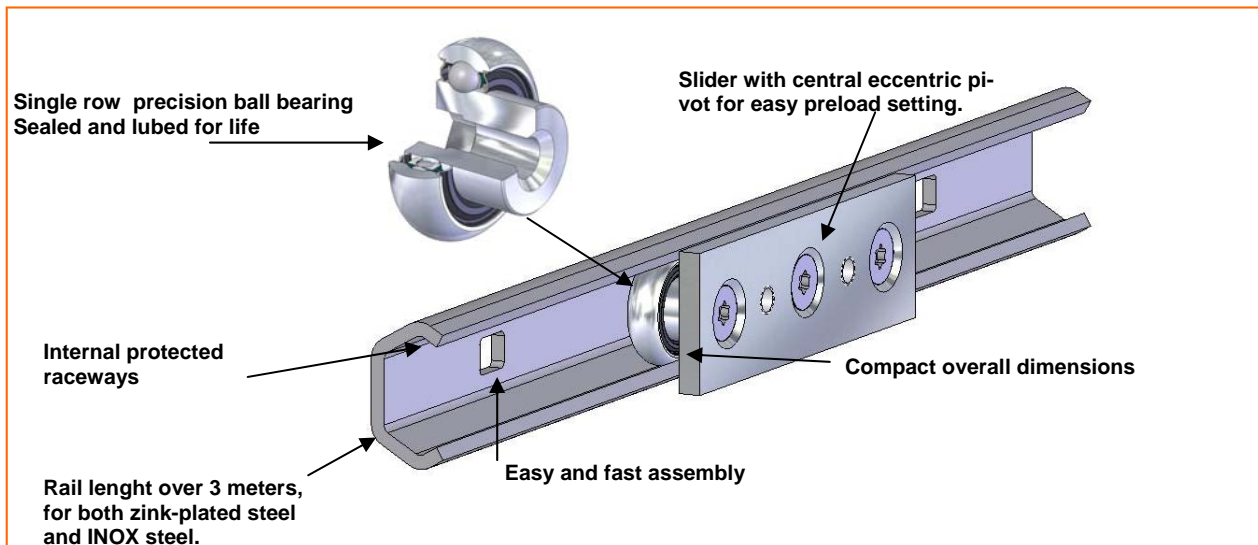

LAX series in stainless steel

LAZ series in zinc plated iron sheet



LAX series

The new rails (LAX series) and its roller slider (PAX series) are made completely in stainless steel. They are designed for general light load applications, where high resistance against corrosion is required; i.e. food-industry, medical equipment, out-door application etc. Suitable for maritime applications, ambients with corrosive agents or applications which require frequent complete wash-down. Also suitable also for clean-room applications.

LAZ Series

The new rails (LAZ series) and its roller slider (PAZ series) are made in zink-plated steel with hardened bearings. Dimension wise of same size as the I-NOX version, but considerable much more economical. They are designed for simple low-load applications, combining smooth movement with in-expensive linear bearings in various fields. Suitable also for high temperature application, due to non presence of plastic parts and specific bearing grease. The compact design, protected raceways, easy assembly together with a high ratio of performance vs price, make this solution one of the most advantageous solutions on the market.

Technical Characteristics

- Rolled steel rail in non-magnetic Inox AISI 304 .
- The rollers are made in hardened INOX AISI 440C, with 2RS seals and lubed for life with mineral oil for alimentary applications.
- Slider body in non-magnetic INOX AISI 304
- Screws in non-magnetic INOX AISI 304.
- Operating temperature $-30 + 110C^{\circ}$
- Slider has adjustable eccentric central roller for easy preload adjustment, for smooth movement without clearance.

Technical Characteristics

- Rolled steel rail with bright zink-plating.
- The rollers are made in standard hardened bearing steel, with 2Z seals and lubed for life with high temperature mineral grease.
- Slider body in bright zink-plating steel.
- Screws in bright zink-plated steel.
- Operating temperature $-40 + 130C^{\circ}$
- Slider has adjustable eccentric central roller for easy preload adjustment, for smooth movement without clearance.

Rail dimensions

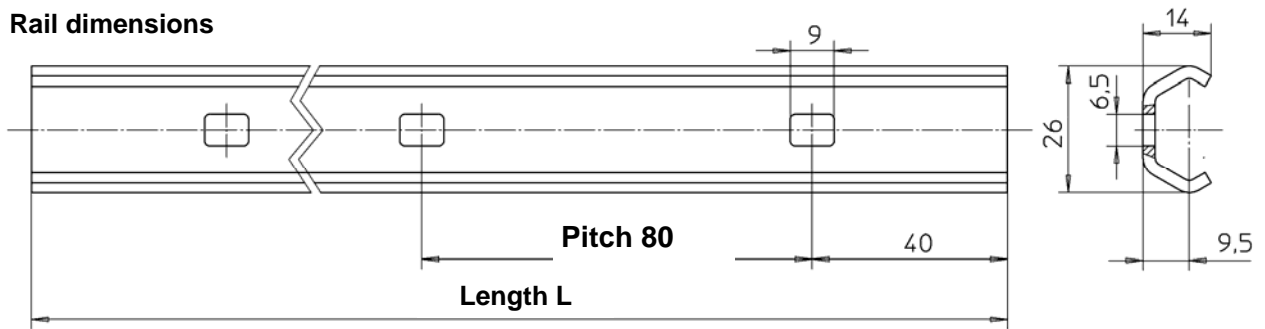

Rail code	Length *(mm)				
LAX 26	1040	1520	2080	2560	3120
LAZ 26	1040	1520	2080	2560	3120

* Other lengths on request

Fixing screws with half circle head, M5 ISO 7380

Rail type

Length

Order code : PAX 26-1040

Slider dimensions

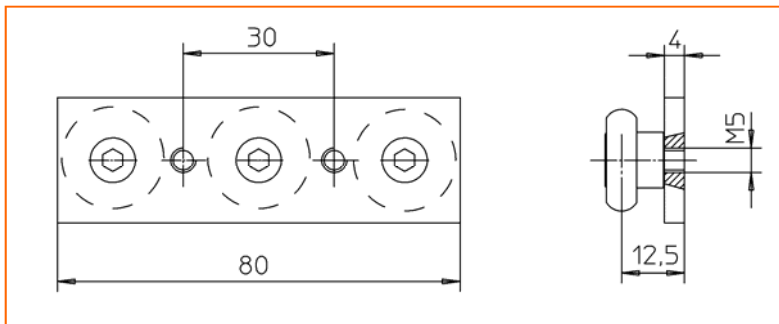

Installation dimensions

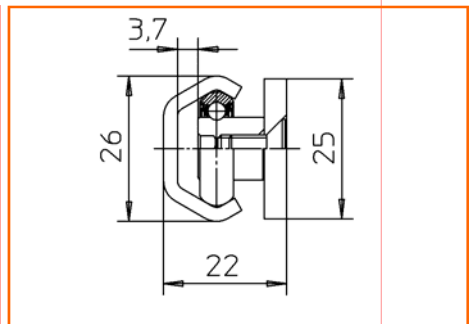

Slider code	Co rad. (N)	Co ax. (N)	Weight (g)
PAX 26-3	800	400	103
PAZ 26-3	800	400	103

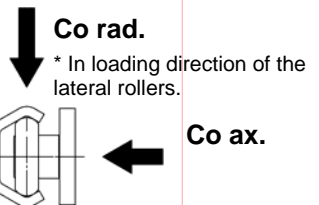

Co rad.

* In loading direction of the lateral rollers.

Co ax.

Preload adjustment

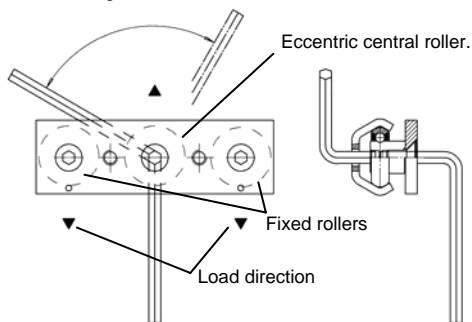

The preload adjustment is done through the sliders central eccentric roller. After having inserted the slider into the rail, it is possible to adjust the preload, by the central roller against the opposite raceway with 2 Allenkeys. The regulation must be done before rail fixing as one Allenkey must be inserted through the rail fixing hole, into the pivot of the central roller. See left illustration. During rotation of the eccentric roller, it is necessary to keep the fixing screw (at slider body) a bit tightened until contact with the raceway opposite the 2 lateral rollers. After achieving a light contact of the eccentric roller, the Allenkey behind the rail is kept firm while tightening the fixing screw. The slider is then moved along the whole rail to assure smooth movement without clearance. If too tight or some clearance, re-adjustment must be carried out.

Tightening tougue : 7 Nm

Roller dimensions

Roller code	Type	Material	Seals	Co rad.(N)	Weight (g)
PCX 26	Concentric	Inox	2RS	400	13,5
PEX 26	Eccentri	Inox	2RS	400	13,5
PEX 26	Concentric	Steel	2Z	400	13,5
PEZ 26	Eccentric	Steel	2Z	400	13,5

